

Pay close attention to the orientation of the drone frame. Note that the front has a small tab sticking out and the back has a small recess.

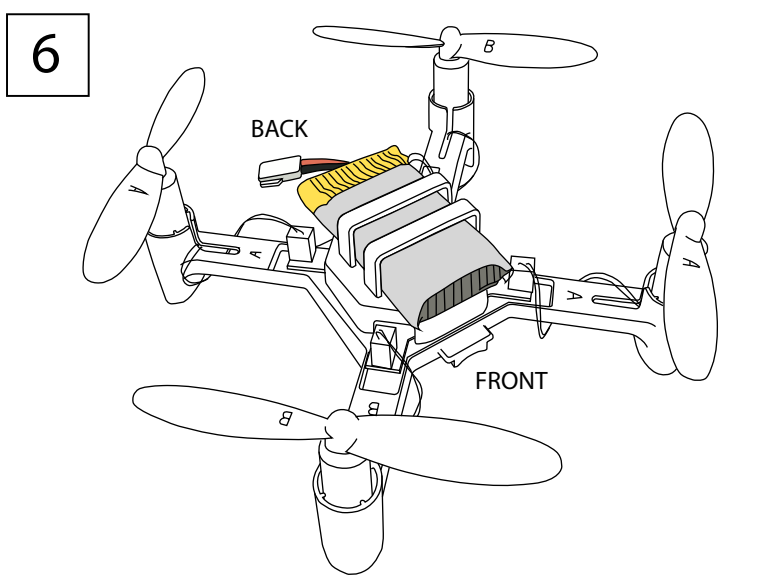

Match A to A, B to B. If your propellers have numbers, disregard them.

1. CONTROLLER

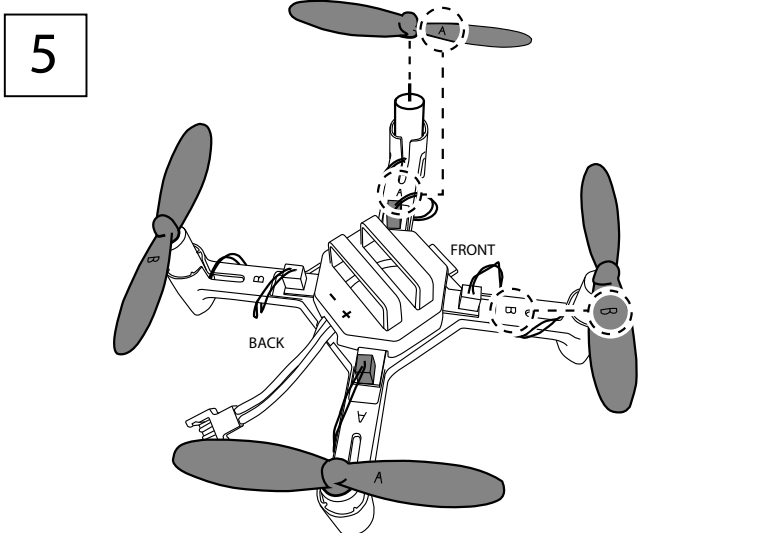
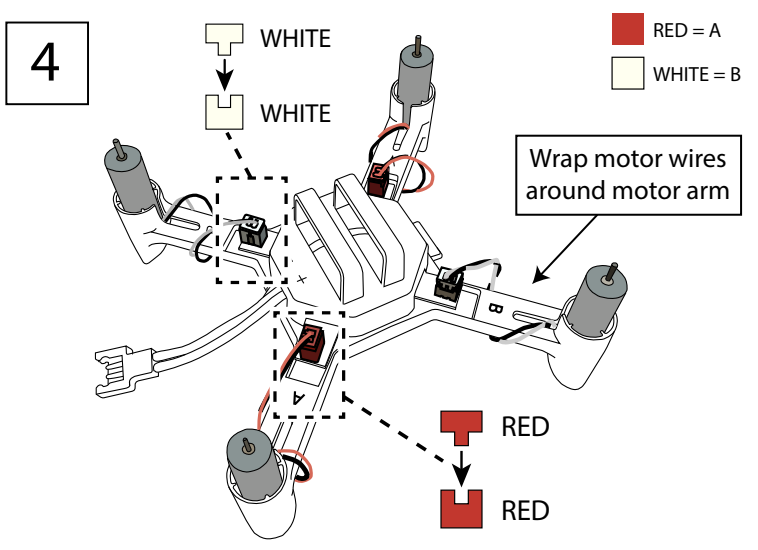
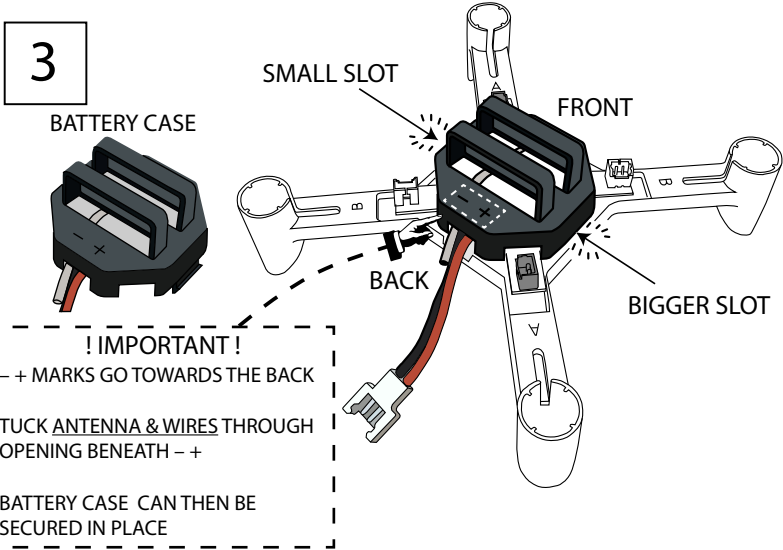
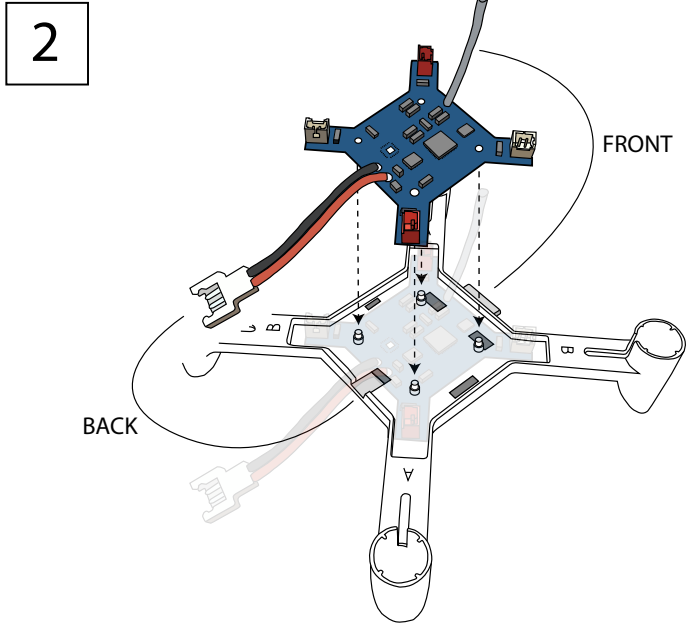
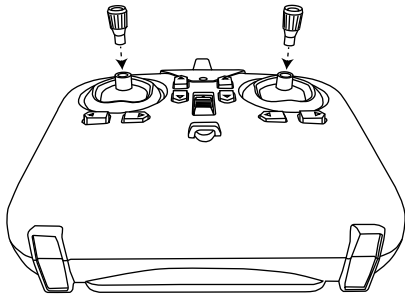

1. Insert the included knobs into the control gimbals. They should twist all the way down and feel snug.

2. POWER

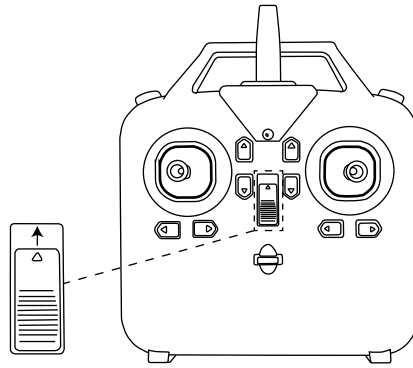

1. Turn controller on. (Red light will flash)
2. Place drone on flat, level ground free of obstructions and plug drone battery in. (Red & blue lights will flash on drone)

3. PAIRING

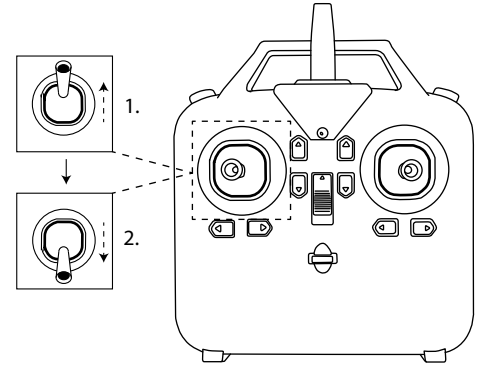

1. Push throttle stick all the way forward.
2. Pull throttle stick all the way back. (Red & blue lights on drone turn solid)
Your drone and controller are now paired on the same radio frequency.

4. CALIBRATION

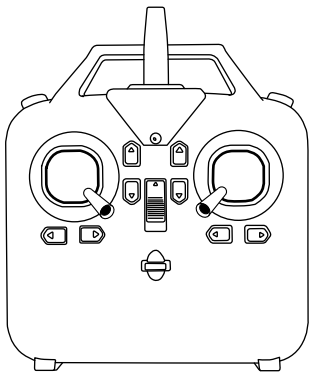

1. Push both sticks inwards and downwards. (Drone lights will rapidly blink then turn solid)
Your drone is now calibrated.

5. ARM/DISARM

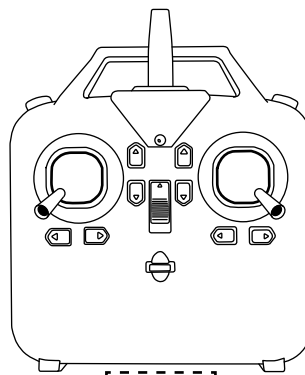

CAUTION

Spinning propellers on this step

Make sure you stand away from the drone and wear safety glasses. Ensure the drone is placed in an open space free of obstructions and review CONTROLS before arming.

1. Push both sticks outwards and downwards. Drone propellers will spin slowly.
2. Apply throttle (push forward on left stick), and drone will takeoff.

6. CONTROLS

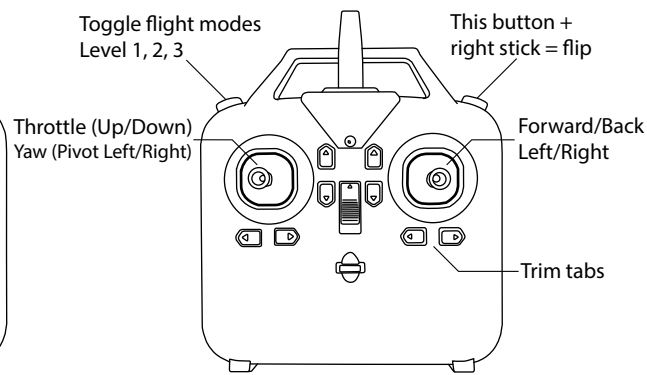

Battery Charging

1. Plug included charger into USB 2.0 port (phone charger brick)
2. Connect battery to charging cable
A solid red light indicates the battery is charging
No light indicates charging is complete

Troubleshooting

- Q: "My drone wants to roll to one side"
A: The drone needs to be recalibrated. Place drone on level, flat surface and repeat POWER, PAIRING, CALIBRATION steps.
- Q: "The propellers spin, but the drone will not take off or will flip over upon arming."
A: Ensure the correct propellers are on the right motors. Ensure the red/white motor cables are plugged into the corresponding red/white ports on the flight controller. Make sure to match the 'A' or 'B' propellers to the corresponding 'A' or 'B' motors as shown in Step 5.

Information

The drone usually takes about 20-30 minutes to charge.
The drone's flight time is about 3-5 minutes.
The drone can fly outdoors, but always fly safely!
The drone lights will flash in flight when the battery is low.

For any questions, please reach out to us at:
makeadrone.com/help

